

Grohe Essentials Reserve toilet paper holder



Range: Essentials

Description: The GROHE Essentials Spare Toilet Paper Holder in Brushed Hard Graphite – convenient comfort and style! - material: metal, wall mounted, concealed fastening, GROHE Long-Life finish, suitable for screwing (including screws and dowels) or gluing (glue 40 915 000 sold separately), holding force: max. 5 kg, the specified holding capacity is valid for static (slowly applied) load and intended use only

Product Code: G-40385AL1

ERP Code: G-40385AL1

Barcode: 4005176429750

Product Features: 5 Year Warranty, GROHE Long-Life finish

Dimensions:

(l) 385mm x (w) 210mm x (h) 130mm

Package Weight: 0.42

CAD3D: [Download](#)

Product Images

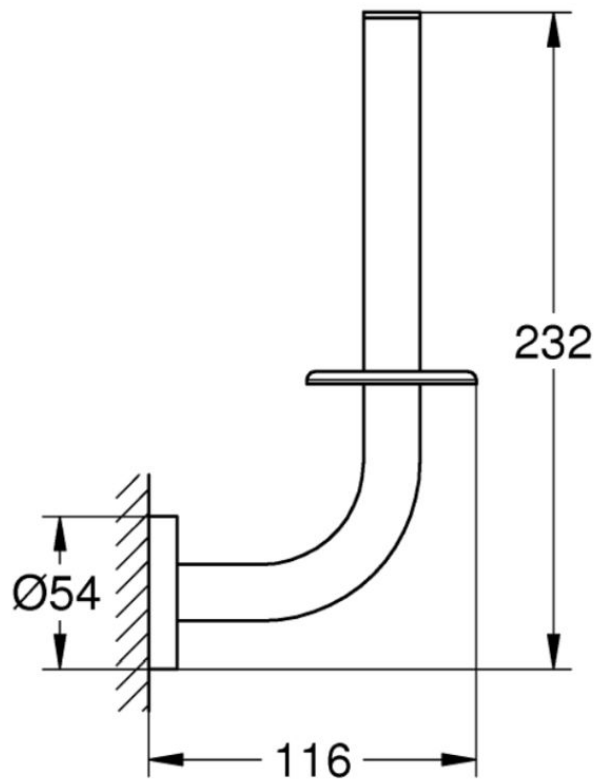
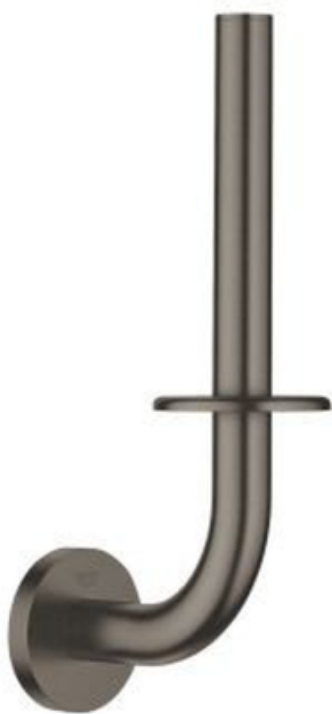

MOT



5 Year Warranty



GROHE Long-Life
finish