

Grohe Essentials Reserve toilet paper holder



Range: Essentials

Description: The GROHE Essentials Spare Toilet Paper Holder – convenient comfort and style! - material: metal, wall mounted, concealed fastening, GROHE Long-Life finish, suitable for screwing (including screws and dowels) or gluing (glue 40 915 000 sold separately), holding force: max. 5 kg, the specified holding capacity is valid for static (slowly applied) load and intended use only

Product Code: G-40385001

ERP Code: G-40385001

Barcode: 4005176326356

Product Features: 5 Year Warranty, GROHE Long-Life finish

Dimensions: (l) 235mm x (w) 125mm x (h) 70mm

Package Weight: 0.42

CAD3D: [Download](#)

Product Images

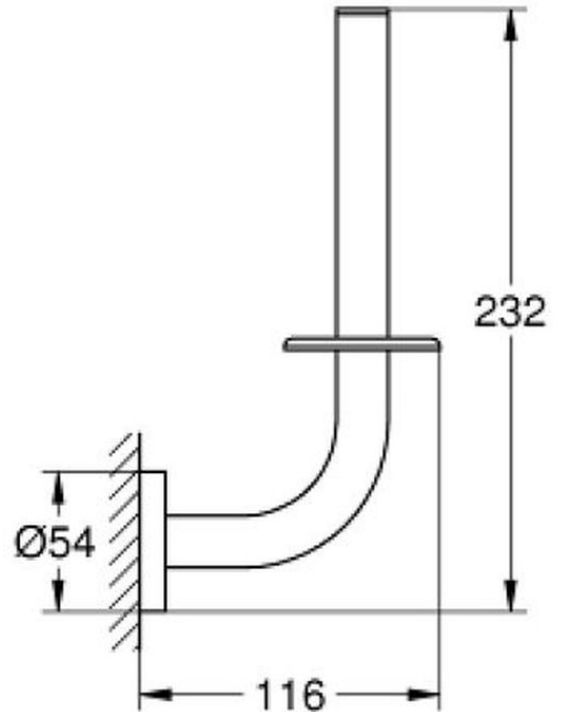

MOT



5 Year Warranty



GROHE Long-Life
finish