

Grohe Tempesta 110 Shower Rail Set 2 Sprays (Rain, Jet)



Range: Tempesta 110

Description: This GROHE Tempesta 110 shower set in a stunning matt black finish is easy to install and use, but offers a completely transformative showering experience and eye-catching aesthetics. The 110mm diameter hand shower features 2 sprays to suit different moods: soothing Rain eases stress, while the focused Jet is ideal for rinsing hair after shampooing. Both are easy to access using the innovative GROHE SmartSwitch diverter on the back of the shower head. GROHE DreamSpray technology ensures that the flow of water from every nozzle is equal, for a perfectly balanced spray pattern. The ShockProof silicone ring is there to prevent the hand shower itself, or the shower tray or bathtub, being damaged if it's dropped. GROHE Water Saving technology significantly reduces water usage without compromising on performance. A minimum of 0.2 bar of pressure is recommended. GROHE SpeedClean enables you to brush the nozzles free of limescale with just a finger. The package includes the Tempesta 600mm shower rail and the Relexaflex 1750mm shower hose. The sturdy hose is built to revel in hard work and can withstand water pressure up to 5 bar, tension up to 50kg and heat up to 70°C. The smooth surface is easy to clean – one quick wipe with a dry cloth and it looks as good as new – and it won't cause any damage if it comes into contact with the shower cubicle or bathtub. The AntiFold design ensures it won't bend and end up with annoying kinks. The rail comes with a gliding element and swivel holder, so adjusting the height and angle of the shower is super easy. Thanks to the GROHE FastFixation installation system the upper bracket is variable in height, meaning it can be fitted to existing drill holes. And the GROHE Long-Life finish of the shower set is hard-wearing and easy to clean for a flawless surface that will last a lifetime.

Product Code: 261622433

ERP Code: 261622433

Barcode: 4067393015710

Product Features: GROHE DreamSpray, 5 Year Warranty, GROHE Water Saving

Dimensions: (l) 645mm x (w) 145mm x (h) 68mm

Package Weight: 1.155

CAD3D: [Download](#)

Product Images

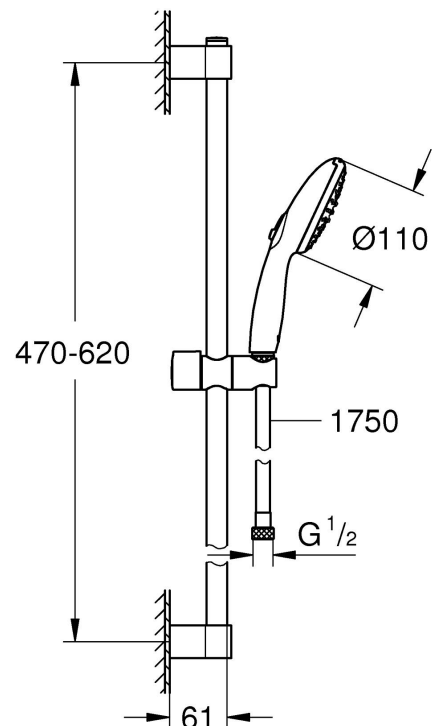

Flow Chart

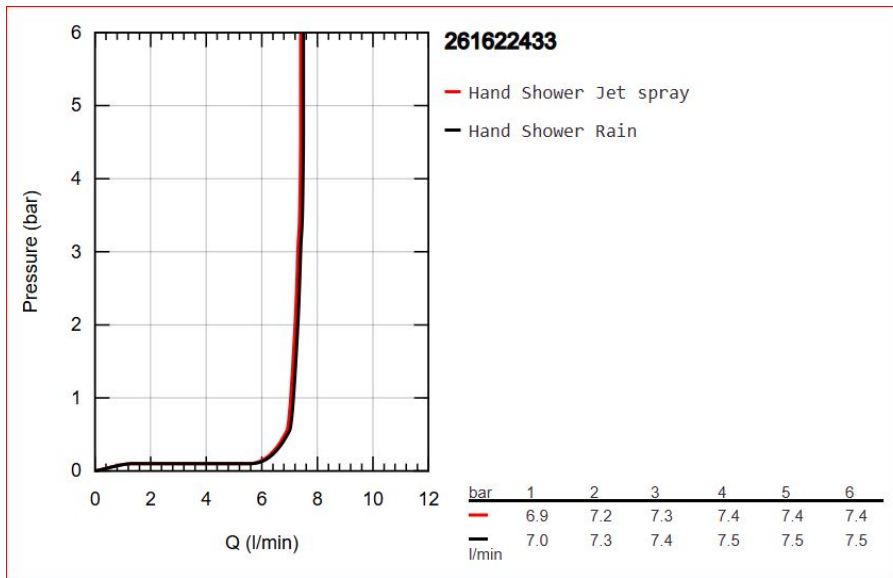

MOT



GROHE DreamSpray GROHE Water Saving 5 Year Warranty