

# Cobra Medical Heavy Pattern Pillartap heavy patt red 15mm CP



**Range:** Medical Heavy Pattern

**Description:** Heavy Pattern Medical elbow-action, square-type pillar tap, chrome. Includes: 1/4 turn ceramic disc head part, red indice, 1/2 BSP male inlet, and flanged backnut. Ideal for medical, kitchen and industrial installations. Care & Maintenance - Ensure your product does not come into contact with any lubricants during installation. Chrome plated, matte black and any colour finishes should be wiped with warm soapy water and a soft cloth or sponge. Rinse, then dry and buff with a dry soft cloth. Under no circumstances must any detergents containing hydrochloric acids or abrasives including cream cleansers be used. Do not use abrasive cleaning materials such as scourers. Should your product have an aerator at the water outlet, it should be checked and cleaned regularly.

**Product Code:** 505-21R/HP

**ERP Code:** 1033730000

**Barcode:** 6002194156864

**Product Features:** Cobra PureShine, Cobra EcoMind, Cobra DefenZR, Cobra TeamAssist, Cobra LowPressure, 20 Year Warranty, JaswicApproved

**Dimensions:** (l) 265mm x (w) 60mm x (h) 110mm

**Package Weight:** 0.8

## Product Images

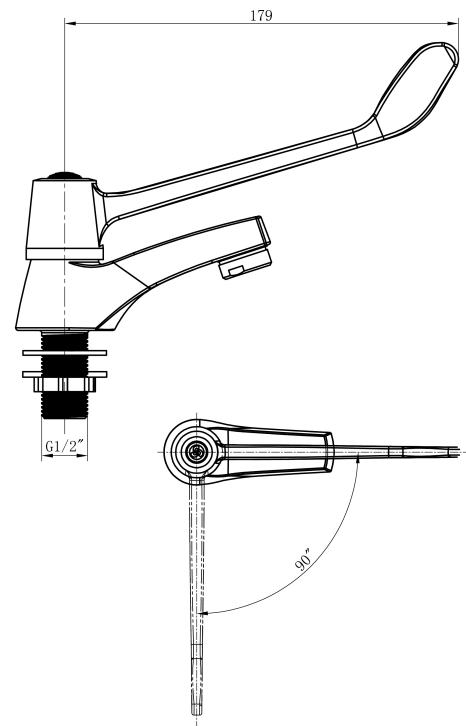

## Flow Chart

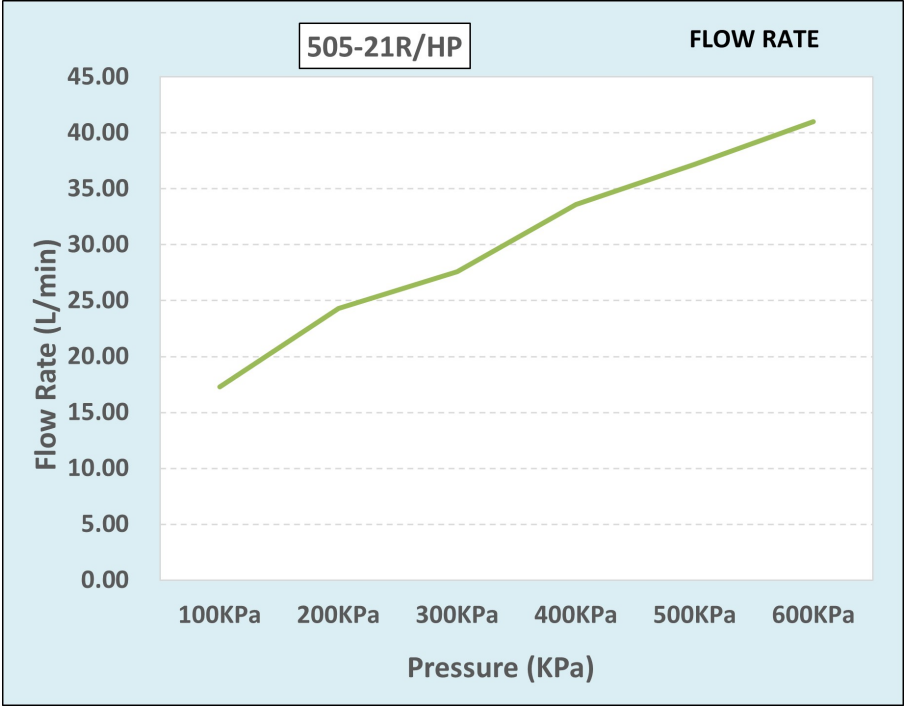

MOT



Cobra TeamAssist



Cobra EcoMind



Cobra PureShine



Cobra DefenZR



Cobra LowPressure



20 Year Warranty



JaswicApproved