

Cobra Arrive Raised Basin Mixer



Range: Arrive

Description: Arrive single lever raised basin mixer for counter top basins. 270mm high from base to top of lever. Pillar type with single hole. Manufactured with dezincification resistant (DZR) brass. Chrome plated finish. 15mm flexi-connection ends. 35mm ceramic disc cartridge. Fitted with Neoperl aerator with a flow rate = 5.7 litres/min. Carries a 20 year warranty. Jasvic Approved Care & Maintenance - Ensure your product does not come into contact with any lubricants during installation. Chrome plated, matte black and any colour finishes should be wiped with warm soapy water and a soft cloth or sponge. Rinse, then dry and buff with a dry soft cloth. Under no circumstances must any detergents containing hydrochloric acids or abrasives including cream cleansers be used. Do not use abrasive cleaning materials such as scourers. Should your product have an aerator at the water outlet, it should be checked and cleaned regularly.

Product Code: 5925CH/N

ERP Code: FBN1D8BO-0GP01

Barcode: 6002194052357

Product Features: Cobra PureShine, Cobra EcoMind, Cobra FeatherTouch, Cobra

TeamAssist, DZR Brass, 20 Year Warranty, New Arrive, JasvicApproved

Dimensions: (l) 310mm x (w) 180mm x (h) 65mm

Package Weight: 1.72

Product Images

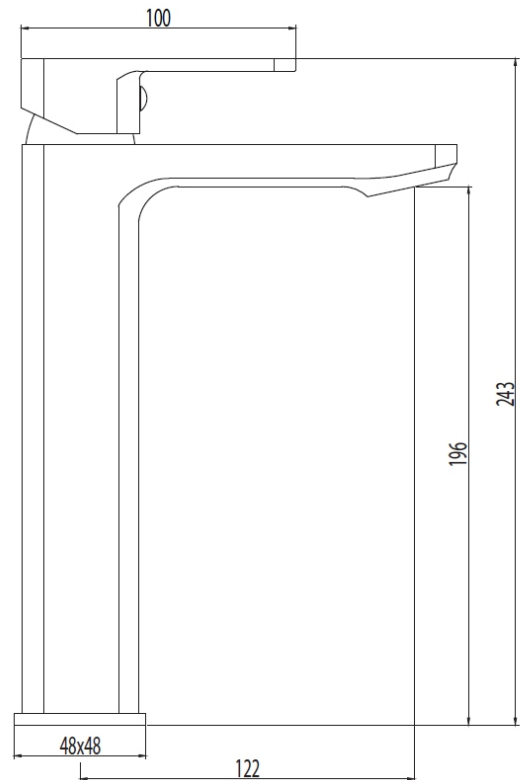

Flow Chart

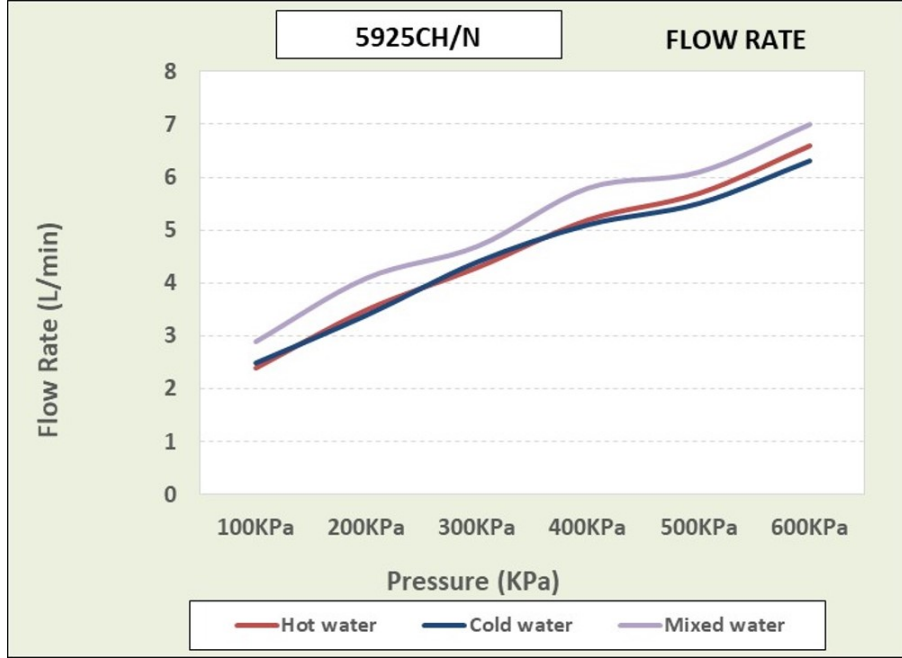

MOT



20 Year Warranty



Cobra EcoMind



DZR Brass



Cobra PureShine



Cobra FeatherTouch



JaswicApproved



Cobra TeamAssist